

4Post and 2Post Rails for Dell PowerEdge Servers

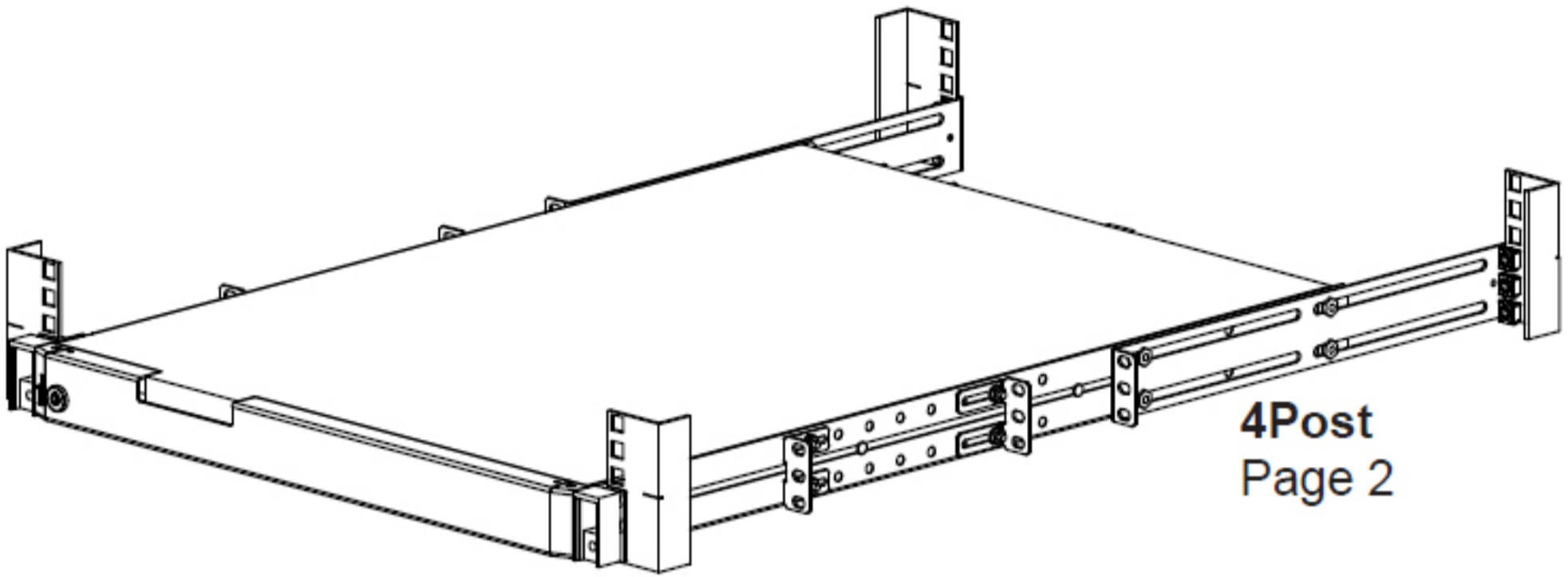

4Post
Page 2

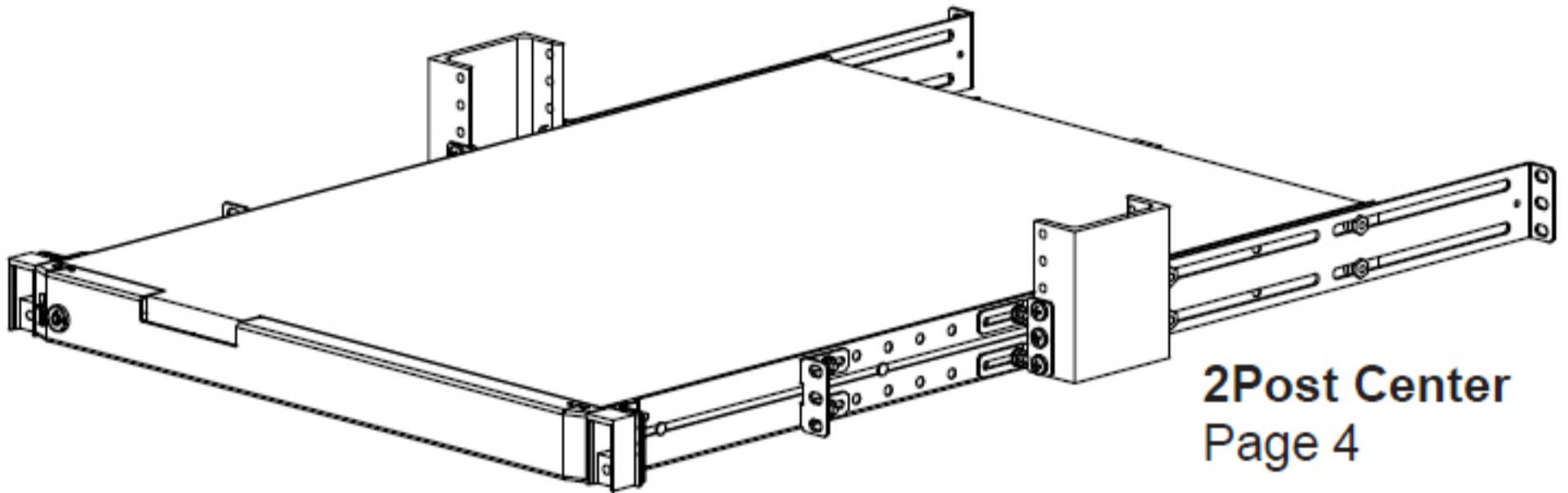

2Post Center
Page 4

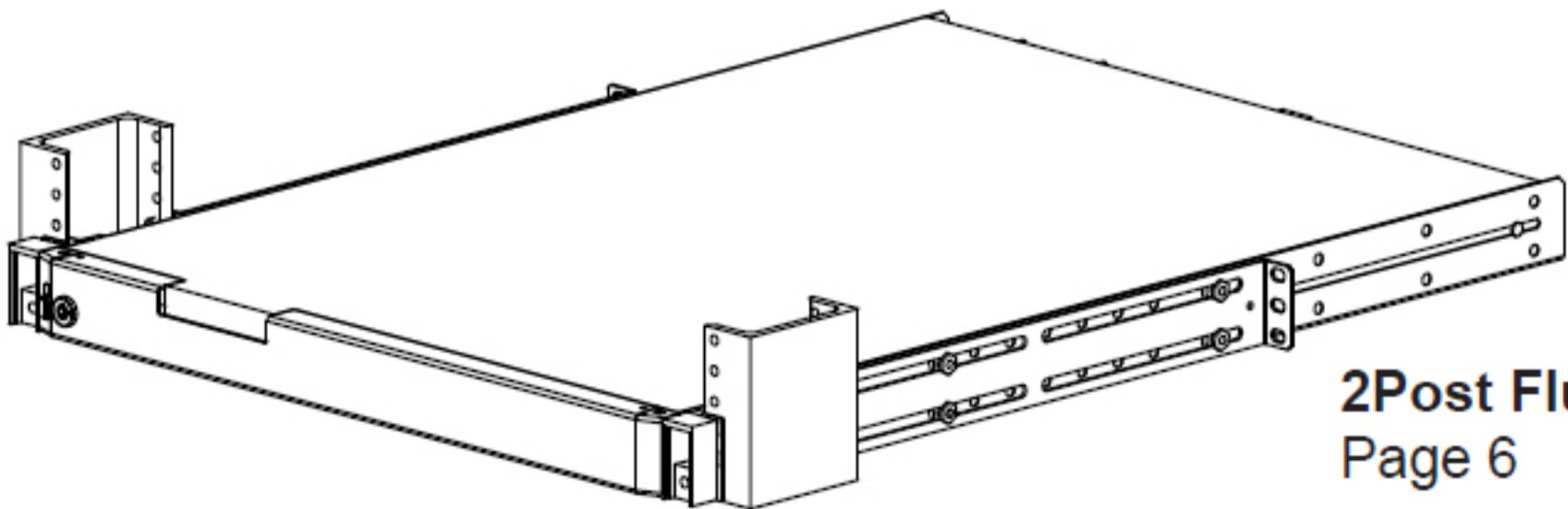

2Post Flush
Page 6

Installation Instructions

Kit Contents

Kit Contents:

- (1) Right Rail Assembly
- (1) Left Rail Assembly

Mounting Hardware:

- (2) Hook Plates (Left & Right)
- (4) 8-32 x .500 Pan Head
- (12) 10-32 x .500 Pan Head
- (12) 12-24 x .500 Pan Head
- (6) 2-24 Cage Nut

4Post Installation Instructions

Step 1. Install cage nuts as shown at the rear of a square hole rack: (6) 12-24 black cage nuts.

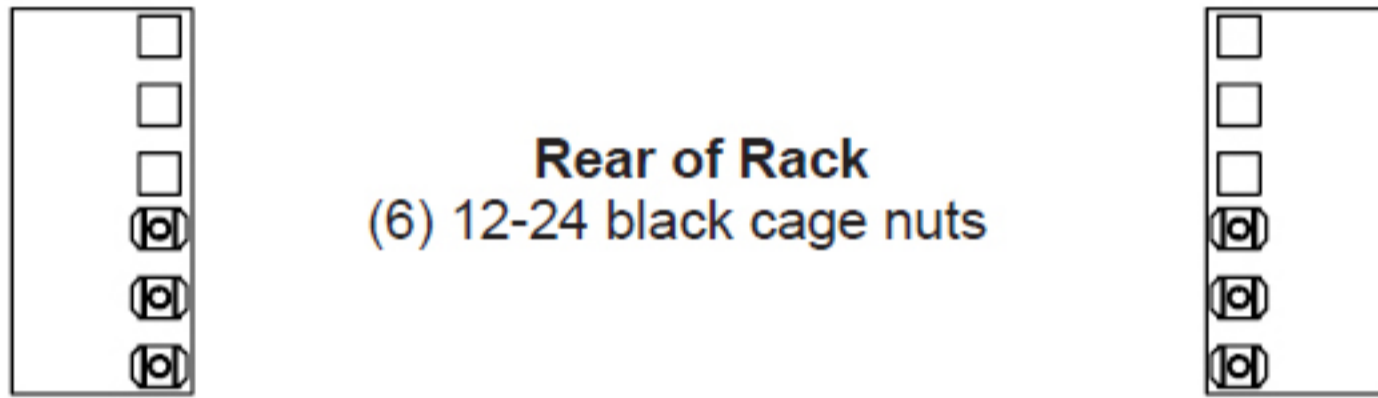

Step 2. The rail kit is pre-set for rack depths of 25.75" to 31.5" [654mm to 800mm]: If your rack is less than 25.75" [654mm] deep, move the hardware attaching the Rear Slider brackets to get the needed adjustment range. Moving the hardware attaching the Rear Slider can achieve any depth from 13" to 31.5" [330mm to 800mm]. The Angle Bracket(s) may need to be removed.

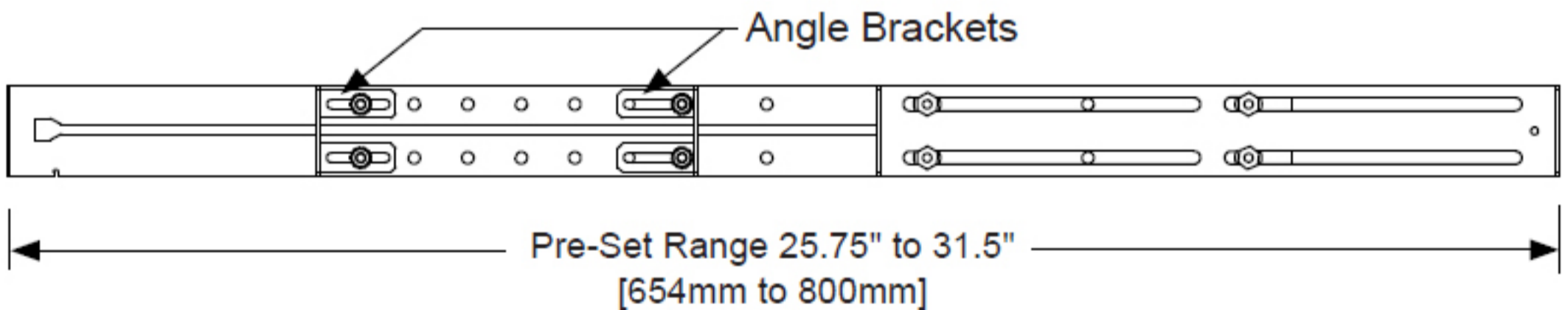

4Post Installation Instructions

Step 3. Attach the front and rear of both rails to the rack using supplied screws at each rail end: Tighten the front and rear Pan Head Screws on the right side rail. Leave the front and rear Pan Head Screws on the left side rail slightly loose.

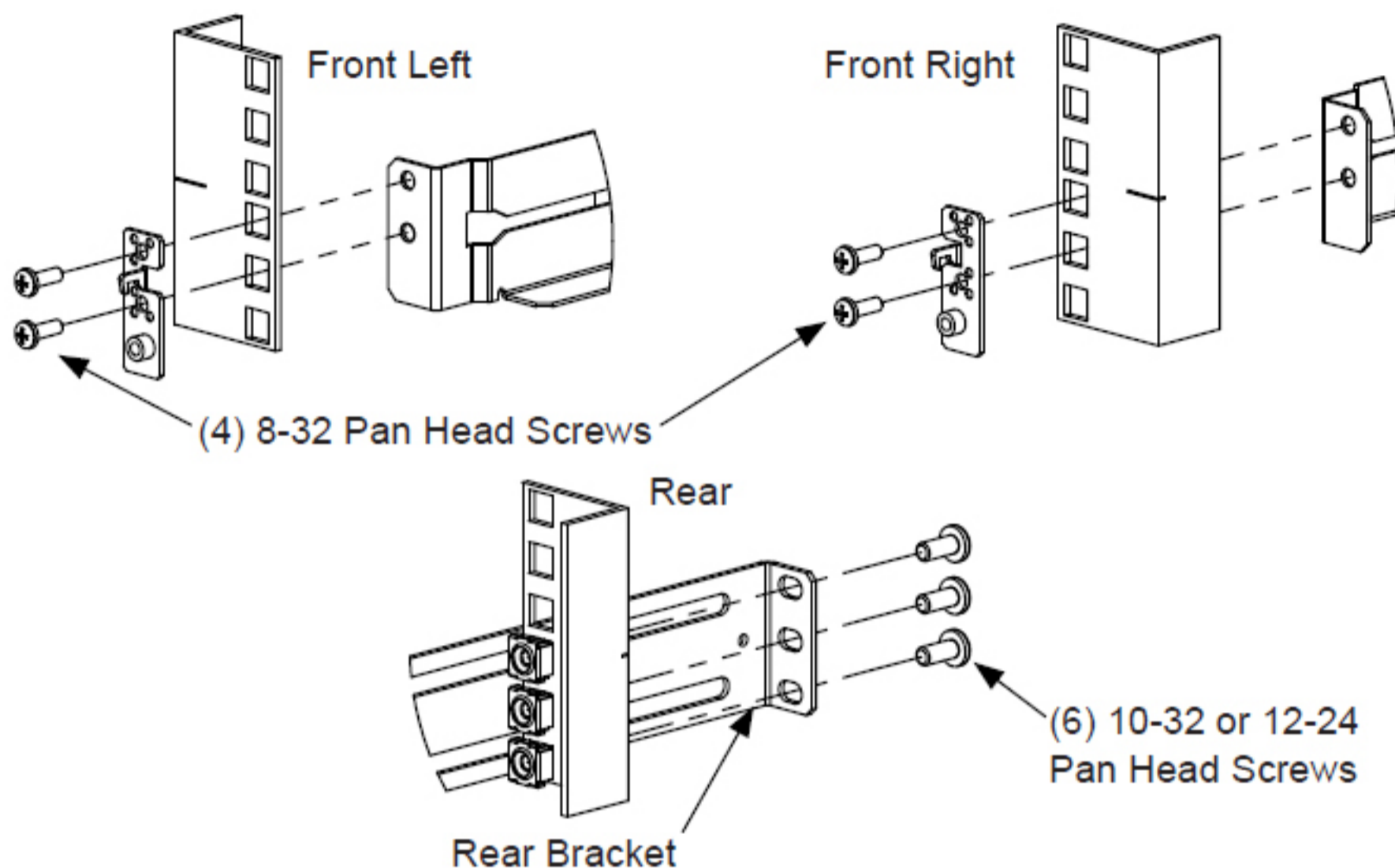

Step 4. Install the equipment using two people: With one person on each side of the equipment, slide the equipment onto the rails so the Equipment Mounting Lugs on each side slide into the Rail Slot on both sides. Slide the equipment all the way in. Tighten the (3) Pan Head Screws on the back of the left slide rail. Slide the equipment out about 8 inches and tighten the (2) Pan Head Screws on the front of the left slide rail.

Note: When tightening the loose rails, support the bottom of the server to ensure proper rail adjustment.

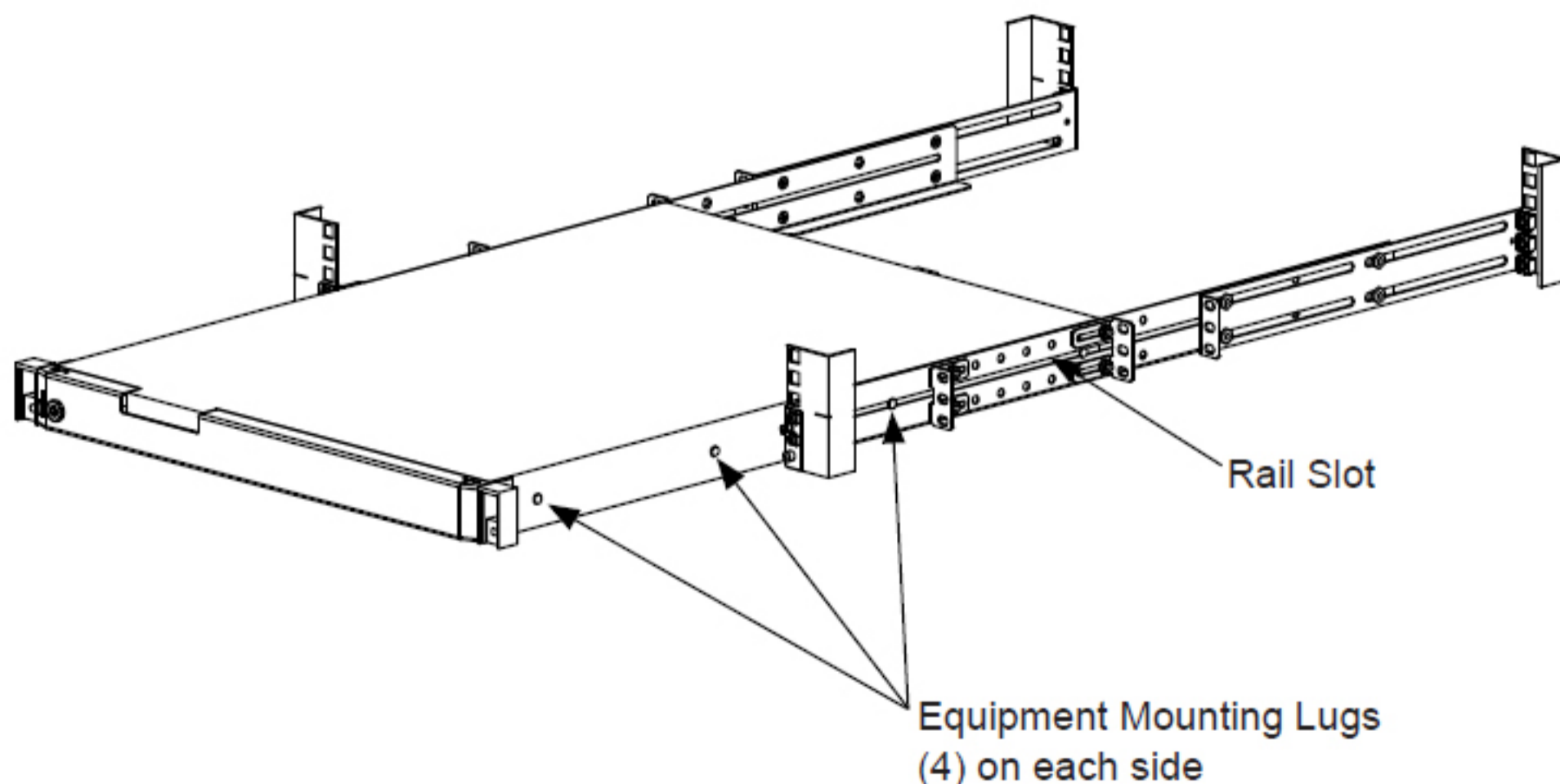

2Post Center Installation Instructions

Step 1. Installing Rail Kit: Installing this rail kit in a 2Post center rack may require a change to the pre-assembled rail configuration as follows (Note: this may require a 3/8" wrench or ratchet).

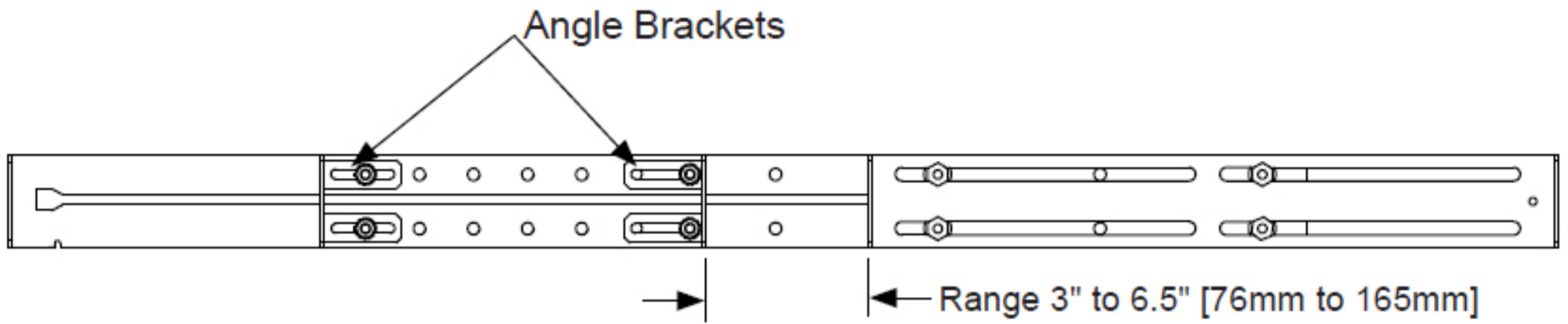

Step 2. Attachment of Hook Plate: Attach the left and right Hook Plate using supplied Pan Head Screws.

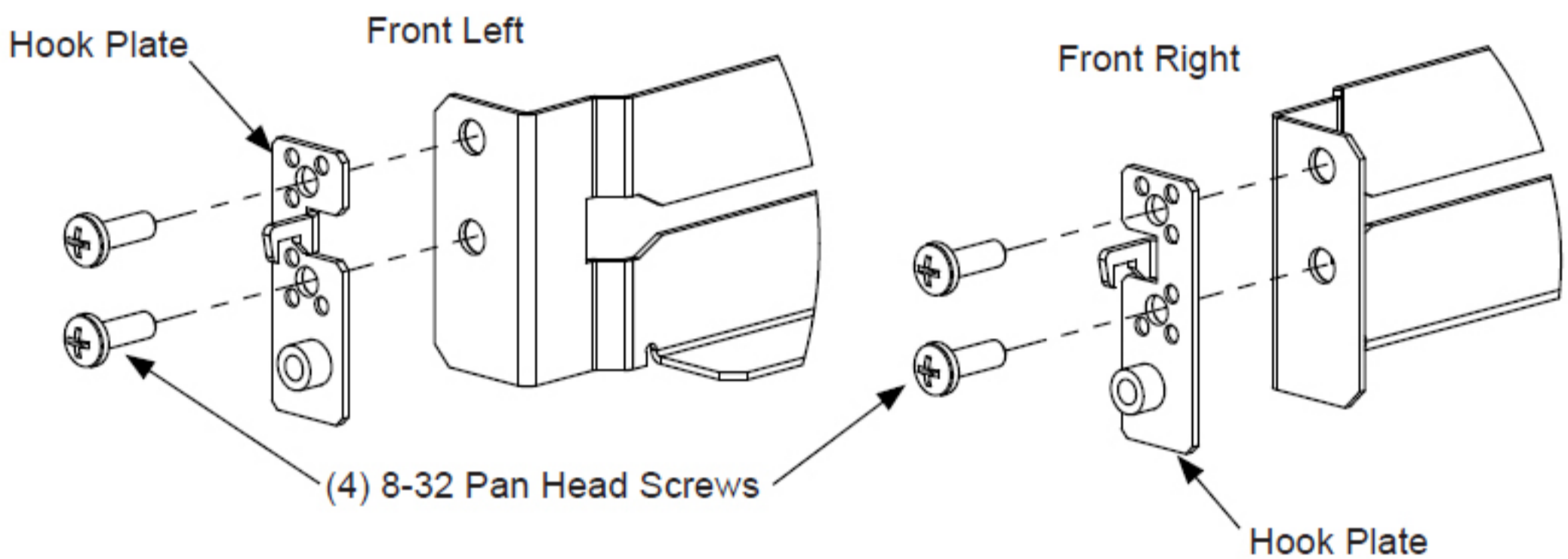

Step 3. Attach the rails to the rack:

- Attach the Front and Rear of the rails to the 2Post rack using (3) supplied Pan Head Screws on each side.
- Tighten the front and rear screws on the right side rail. Leave the front and rear Pan Head Screws on the left side rail slightly loose.

Note: When tightening the loose rails, support the bottom of the server to ensure proper rail adjustment.

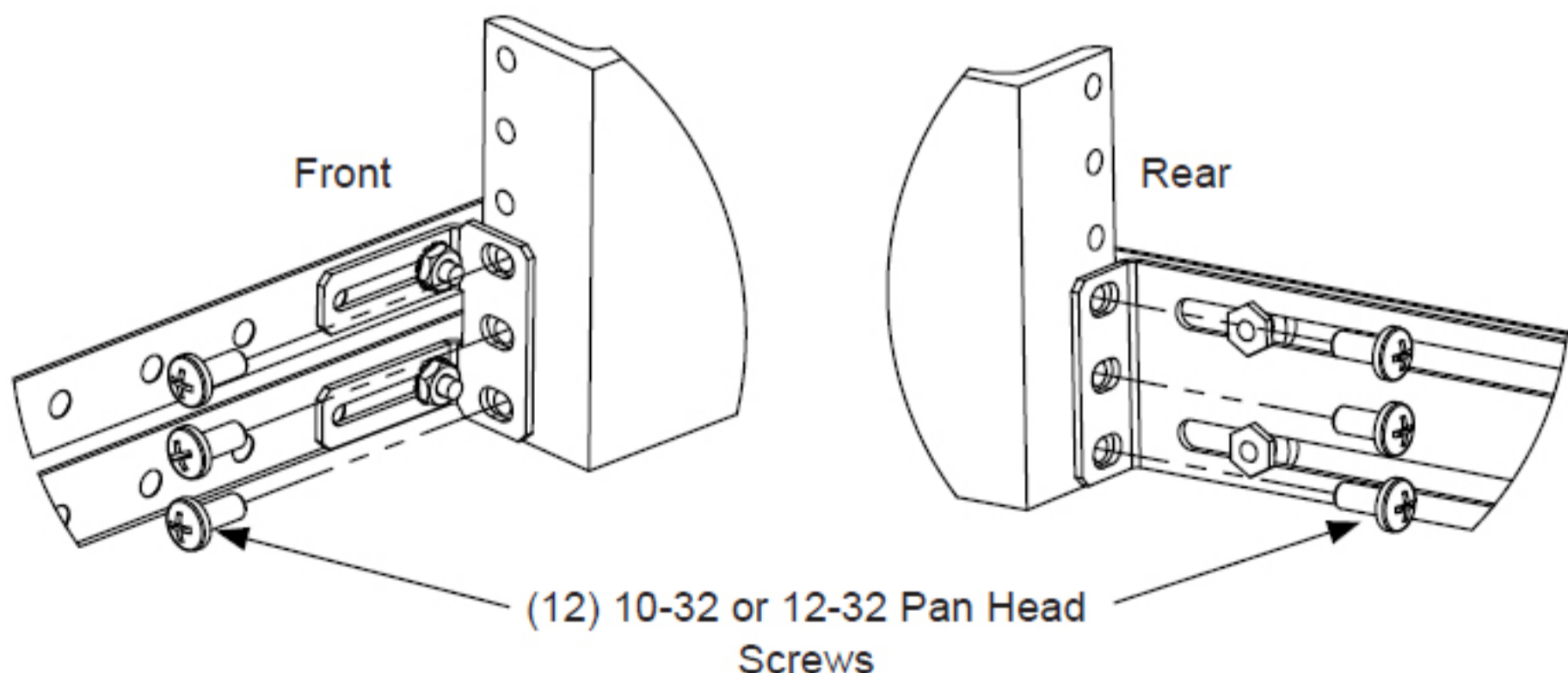

2Post Center Installation Instructions

- Step 4.** Install the equipment using two people: With one person on each side of the equipment, slide the equipment onto the rails so the Equipment Mounting Lugs on each side slide into the Rail Slot on both sides. Slide the equipment all the way in. Tighten the (3) Pan Head Screws on the back of the left slide rail and the (3) Pan Head Screws on the front of the left slide rail.

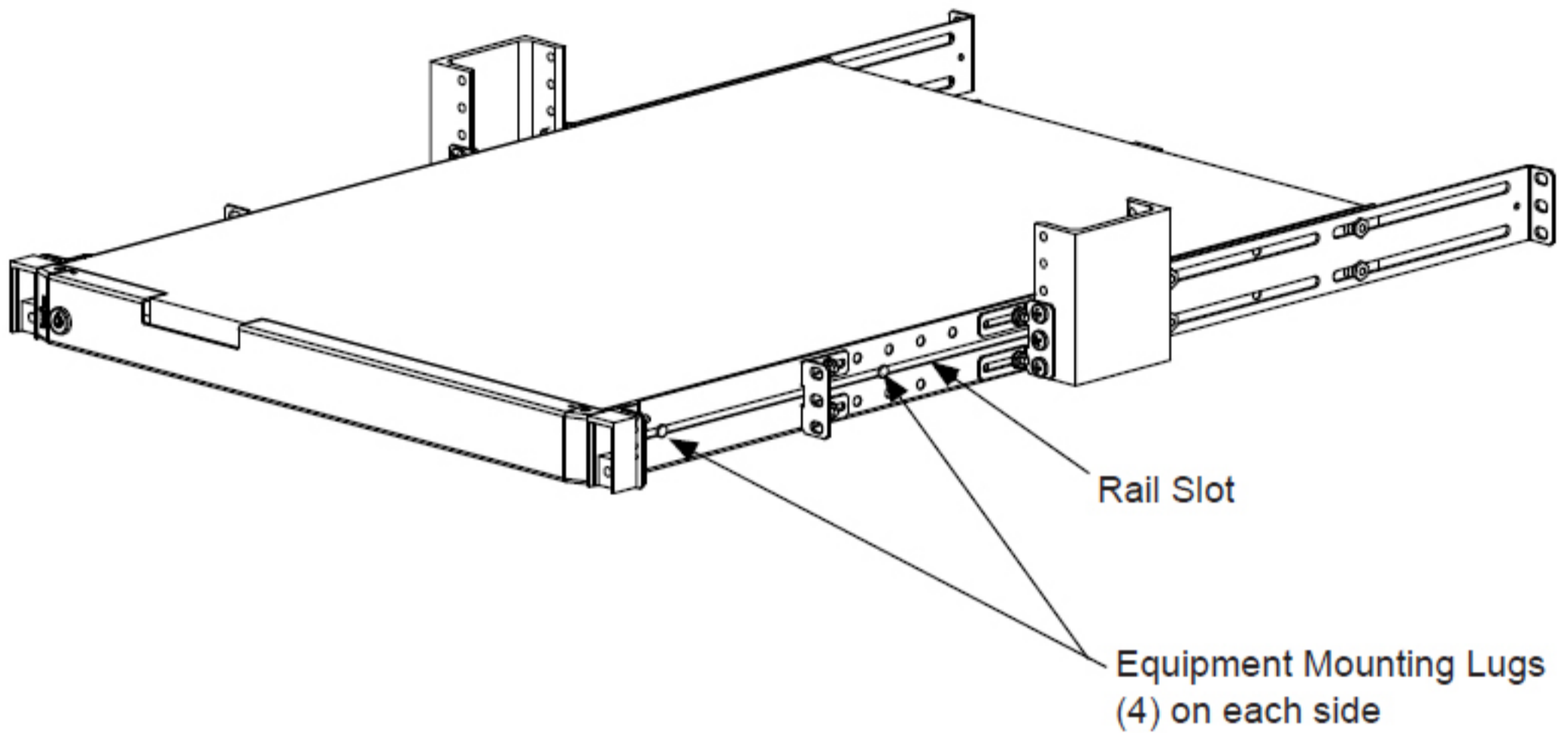

2Post Flush Installation Instructions

Step 1. Install Rails: Installing this rail kit in a 2Post flush rack requires a change to the pre-assembled rail configuration as follows: remove and discard the Angle Brackets and associated hardware from the pre-assembled rails. (Note: this will require a 3/8" wrench or ratchet).

Rail in Supplied Configuration

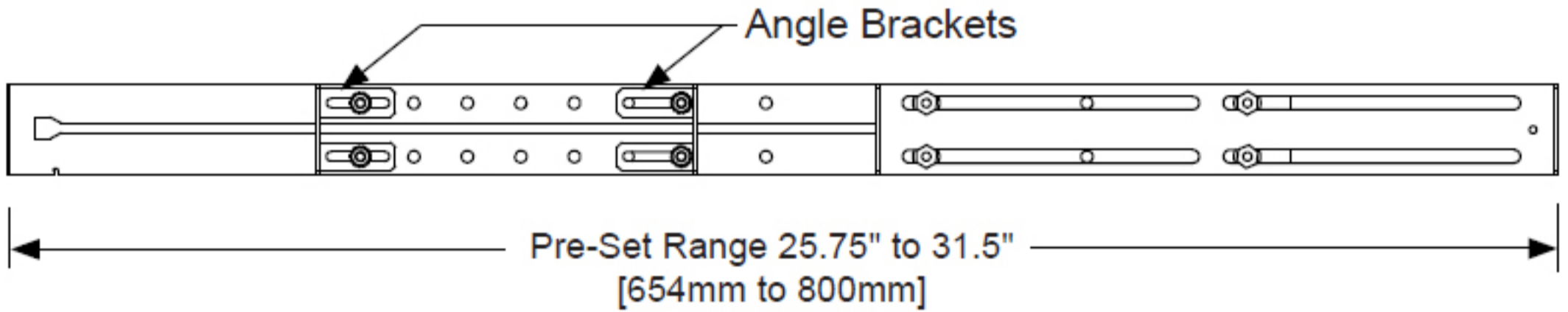

"Right" Rail in the new 2Post Flush Configuration

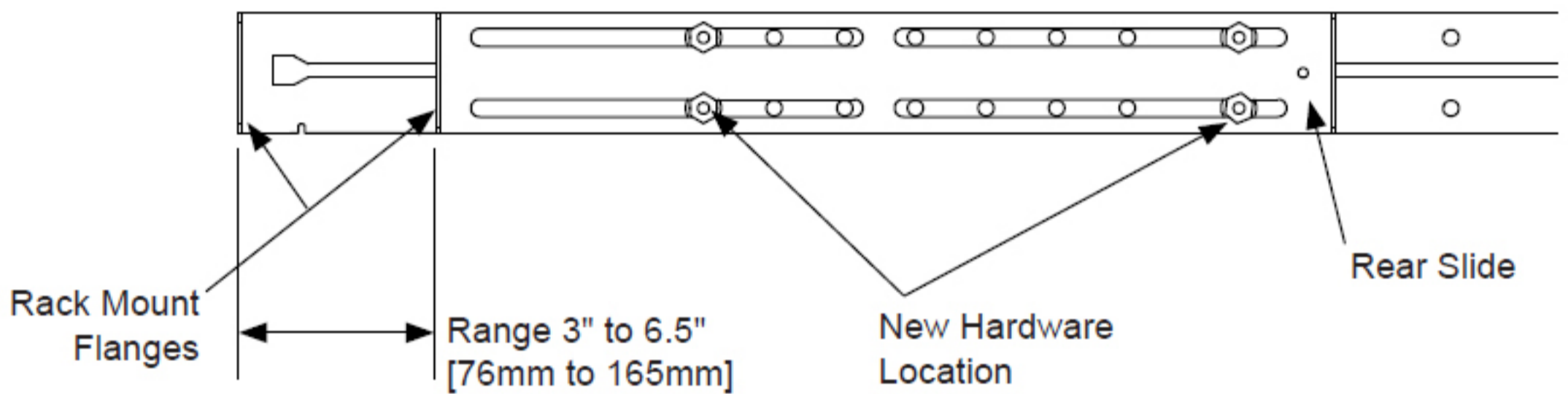

Step 2. Attach the rails to the rack:

- Attach the Front and Rear of the rails to the 2Post rack using (5) supplied Pan Head Screws on each side.
- Tighten the front and rear Pan Head Screws on the right side rail. Leave the front and rear Pan Head Screws on the left side rail slightly loose.

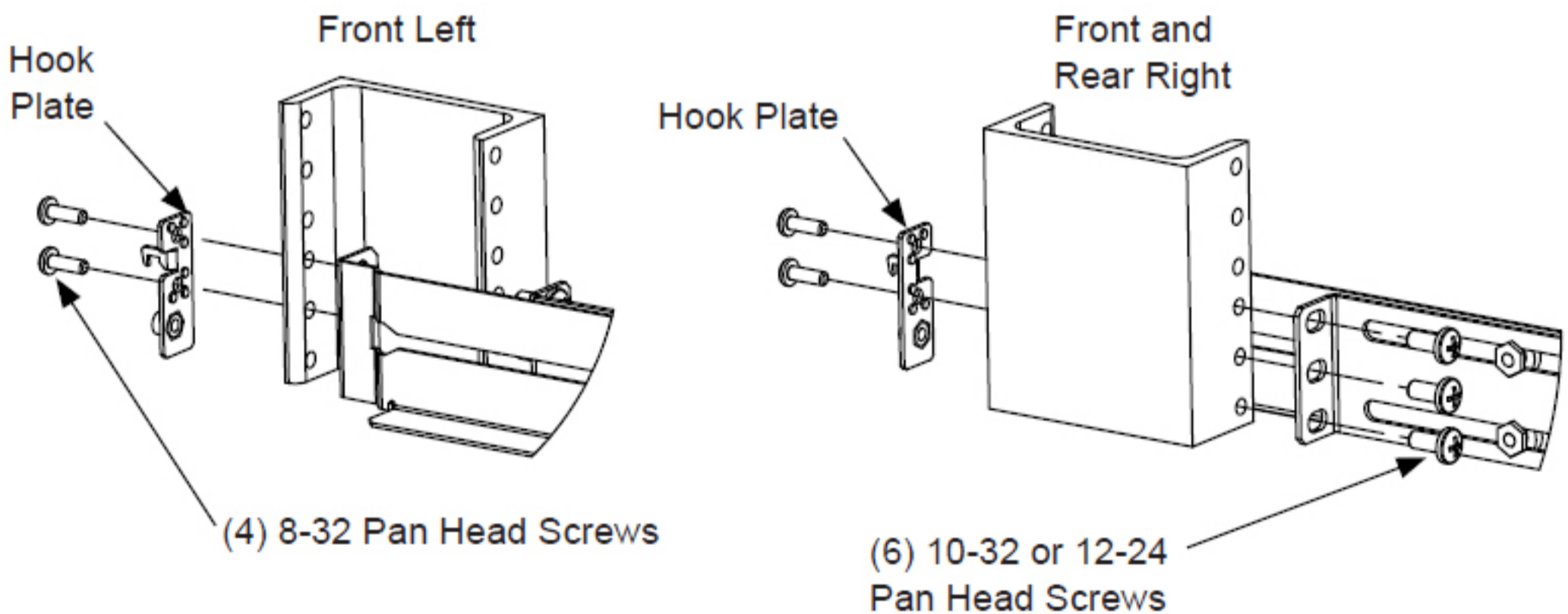

Note: When tightening the loose rails, support the bottom of the server to ensure proper rail adjustment.

2Post Flush Installation Instructions

Step 3. Install the equipment using two people: With one person on each side of the equipment, slide the equipment onto the rails so the Equipment Mounting Lugs on each side slide into the Rail Slot on both sides. Slide the equipment all the way in. Tighten the (3) screws on the back of the left slide rail. Slide the equipment out about 8 inches and tighten the (2) screws on the front of the left slide rail.

